

**QUALITATIVE AND QUANTITATIVE
MULTI-CRITERIA MODELS OF THE IMPORTANCE OF
THE COMPONENTS IN RELIABILITY STRUCTURE OF
A COMPLEX TECHNICAL SYSTEM**

**WIELOKRYTERIALNE JAKOŚCIOWO-ILOŚCIOWE
MODELE WAŻNOŚCI ELEMENTÓW W
STRUKTURZE NIEZAWODNOŚCIOWEJ ZŁOŻONEGO
SYSTEMU TECHNICZNEGO**

Leszek Chybowski

Institute of Ship Power Plant Operation, Faculty of Marine Engineering,
Maritime University of Szczecin,
e-mail: l.chybowski@am.szczecin.pl

Abstract: *The paper presents an example of qualitative and quantitative application of a method for assessing component importance of a reliability structure in the case of a complex technical system based on the example of the subsystem of a marine power plant, that is, a lube oil system for sealing a stern tube. An example of the importance of the analysis considered in terms of not only reliability but also safety (impact of a component failure on human, machine and the environmental safety). Safety is usually analyzed in terms of quality, so the approach of trying to combine quantitative and qualitative estimation has been called a qualitative and quantitative method. A two – criteria importance of components according to the reliability criteria and safety criteria have been determined. The directions for further research have been outlined.*

Keywords: *reliability structure of components, importance analysis, significance of components, safety criterion, maintainability and costs*

Streszczenie: *W artykule przedstawiono przykład aplikacji jakościowo-ilościowej metody oceny ważności elementów w strukturze niezawodnościowej dla przypadku złożonego systemu technicznego na przykładzie podsystemu siłowni okrętowej statku morskiego: systemu oleju smarnego uszczelnienia pochwy wału śrubowego. Przedstawiono przykład analizy ważności rozważanej w aspekcie nie tylko niezawodności ale również bezpieczeństwa (wpływ uszkodzenia elementu na bezpieczeństwo ludzi, maszyn i środowiska). Bezpieczeństwo zwykle analizowane jest w ujęciu jakościowym, tak więc przedstawione podejście próbujące łączyć ocenę ilościową i jakościową nazwano metodą jakościowo-ilościową. Wyznaczono dwukryterialną ważność elementów wg kryteriów niezawodności oraz kryterium bezpieczeństwa. Nakreślono kierunki dalszych badań.*

Słowa kluczowe: *struktura niezawodnościowa elementów, analiza ważności, istotność elementów, kryterium bezpieczeństwa, obsługiwalność i ekonomiczność*

1. Introduction

The theory of reliability, both in terms of statistical and physical failure focuses on the systems operation and allows for effective determination of measures defining reliability, availability and safety. As far as the system as a whole is concerned, the basic measures of reliability have a significant informative value in terms of the proper operation of the system, while in the case of system components such measures provide only general information about their unreliability and except the case of serial reliability structure, they do not provide any description of the impact of a component on the system. The system tolerance of its component failure depends on the reliability of the components and structure of the system in which the component is located [11, 12, 13, 19, 24].

So far there has been developed a number of measures describing the importance of a component in the system reliability structure taking into account the specific importance criterion, including the importance measures of Birnbaum, Fussell-Vesely, Natvig, Bergman, Barlow-Proschan, Lambert, etc. Despite the advanced mathematical (theoretical) device for importance assessment, they create significant application problems [6, 15, 16, 20, 28]. The use of well-known measures of importance is often limited or impossible due to the lack of complete information about the relationships in the system and unreliability of its components making the known importance measures unsuitable for complex technical systems (CTS). CTS are difficult objects to describe because they are [7, 8, 9]:

- renewable or semi-renewable;
- time variable functional and reliability structures;
- complex in their hierarchical structure and multi-level feedbacks [21, 22];
- with partially or totally dependent faults of components;
- for which we know the answers only if they refer to a certain extent and nature of extortion and interference;
- with many types of redundancies (redundancy relations are unknown and form overlapping sets);
- their reliability structure, despite the known outlined basic functional components, is often not known at all or a substantial part thereof [4, 5, 23];

Due to the limited applicability of a number of importance measures for the CTS components it was necessary to develop modern methods to assign importance rankings of components and groups of components in the CTS for the selected importance criteria (Fig. 1.).

The problems, in question, in conjunction with the various definitions of well-known reliability measures of the importance of components in the system reliability structure, due to their comparison, will provide different rankings of component importance. In addition, it is important that time-dependent measures of

importance are analyzed in relation to the lifetime of the system and not points, because for systems with complex structure the importance ranking created on the basis of a specific measure will be different at different times of the system's lifetime. In the further part of the paper there will be presented selected time plots of the most commonly used reliability measures of components importance.

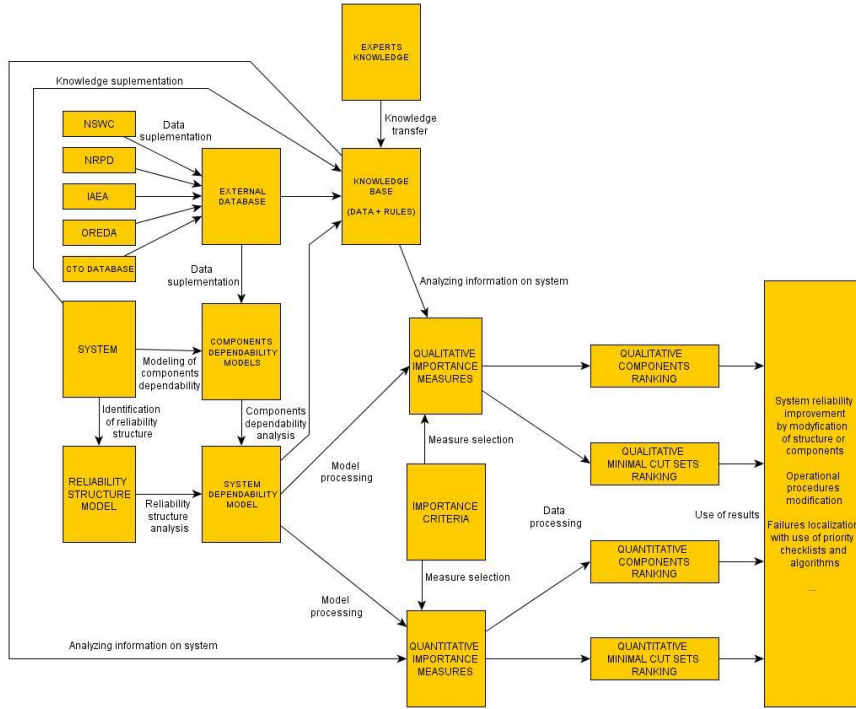

Fig.1. Importance analysis, using qualitative and quantitative models [7].

The initial importance of the components will be determined on the basis of the reliability of a component $F_i(t)$ and the number of path sets x_i , involving the i -th component from all x path sets of the system:

$$I(t) = f[F_i(t), x_i, x] \quad (1)$$

The author suggests the introduction of measures describing the importance of a component, taking into account the relevant criteria, which can be represented by appropriate weighting coefficients for various criteria, such as that of time effort, the effort of staff, the delivery time of spare parts, economics of operation and safety in operation [7, 8, 9]. The importance of the component can be described as a function of:

$$I^{KRYT}(t) = f[F_i(t), x_i, x, c_t(t), c_p(t), c_m(t), c_s(t), c_e(t), c_b(t)] \quad (2)$$

Effort weighting coefficient for the working time of a component renewal has been adopted in the form of:

$$c_i(t) = \frac{t_i(t)}{\max_{k=1..n}[t_k(t)]} \quad (3)$$

with: t - the average recovery time of the i -th component

Weighting coefficient for the participation of the personnel in the component renewal has been accepted as:

$$c_p(t) = \frac{p_i(t)}{\max_{k=1..n}[p_k(t)]} \quad (4)$$

where: p_i – is the average number of people needed to achieve the recovery of the i -th component

The weighting coefficient of the maintainability concerning the renewal of the component took the form:

$$c_o(t) = \frac{t_i(t)p_i(t)}{\max_{k=1..n}[t_k(t)p_k(t)]} \quad (5)$$

Weighting waiting time for spare parts coefficient for the execution of recovery (repair) of the component took the form:

$$c_s(t) = \frac{s_i(t)}{\max_{k=1..n}[s_k(t)]} \quad (6)$$

where: s_i - the average waiting time for delivery of spare parts for the recovery (repair) of the i -th component.

Economics weighting coefficient of operating the component was assumed as:

$$c_e(t) = \frac{m_i(t)}{\max_{k=1..n}[m_k(t)]} \quad (7)$$

where: m - the average total cost of service for the i -th component.

Weighting coefficient of the component operational safety was assumed as:

$$c_b(t) = \frac{b_i(t)}{\max_{k=1..n}[b_k(t)]} \quad (8)$$

where: b - the probability that the failure to the i -th component of the system will lead to the system emergency state.

2. Object of the analysis

The analysis of the importance of the components in a complex technical system was conducted on the example of one of the subsystems of a marine power plant: stern tube seals lubricating oil system of container vessel [29]. The system diagram is shown in Fig. 2.

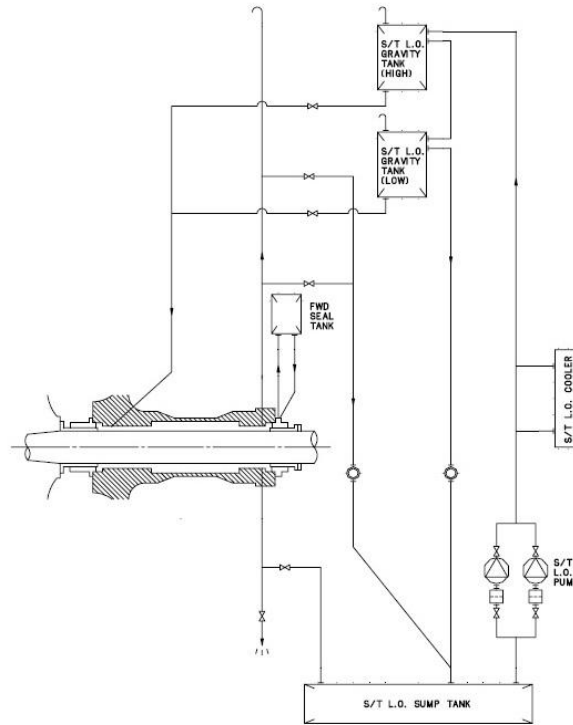

Fig. 2. Stern tube lubricating oil system layout [29].

The reliability structure of the system was modeled, using a reliability block diagrams, as shown in Fig. 3. The structure of the assumed level of decomposition referring to the main components of the system specified in terms of their function in the system and selected as a separate machine or device.

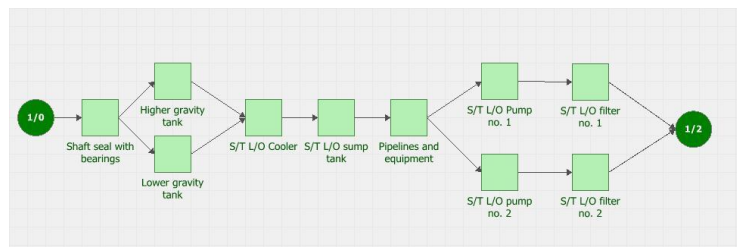

Fig. 3. RBD model of the analyzed system.

Due to the unknown spares in technical systems (hidden redundancies, complex feedbacks, unknown disturbances, etc.), the author proposes a combined model of reliability structure, i.e. the components of the series pre-labeled as negligible and passive are a priori considered as single - component sub - systems. The determinant of the components choice that are outside the single component subsystems will be specific functions of these components, the component structural redundancies, (parallel and thresholds structures), significant at the level of the task realization executed by the system.

The basic reliability data of the system components have been summarized in Table. 1. It was assumed that all the components are renewable objects. Distribution of time to failure is exponential. The accepted failure rate and the average duration of recovery have been taken from [26]. Filter - pump system is duplicated, the analysis has assumed an average value of a failure and renewal process parameters due to the periodic replacement of these devices between the operating and auxiliary systems. It was assumed that the two sub-branches (pumping systems) break down in the same way. A similar assumption relating to the gravity oil tanks has been made.

Table 1. The data of the analyzed technical system components.

<u>Name</u>	<u>Type</u>	<u>Parameter</u>	<u>Value</u>	<u>Description</u>
E1	Repairable	Lambda	2,9170e-005	S/T seal with bearings failure
		MTTR	1,6800e+002	
E2	Repairable	Lambda	1,1140e-005	Higher gravity tank failure
		MTTR	2,4000e+001	
E3	Repairable	Lambda	1,1140e-005	Lower gravity tank failure
		MTTR	2,4000e+001	
E4	Repairable	Lambda	5,7900e-006	Lube oil cooler failure
		MTTR	2,4000e+001	
E5	Repairable	Lambda	1,2050e-005	Lube oil sump tank failure
		MTTR	2,4000e+001	
E6	Repairable	Lambda	8,2130e-005	Pipelines with equipment failure
		MTTR	4,0000e+000	
E7	Repairable	Lambda	1,7495e-004	Pump no. 1 failure
		MTTR	1,2000e+001	
E8	Repairable	Lambda	1,7495e-004	Pump no. 2 failure
		MTTR	1,2000e+001	
E9	Repairable	Lambda	3,0700e-005	Filter no 1 clogged
		MTTR	2,0000e+000	
E10	Repairable	Lambda	3,0700e-005	Filter no. 2 clogged
		MTTR	2,0000e+000	

3. Reliability analysis of the importance of the system components

For the analyzed system at the presented level of decomposition, an analysis of importance components, using the most widely used importance measures, was conducted. Moreover, there has been presented an analysis of the importance of components due to the criterion of failure impact on the system emergency state and a two - criteria importance measure based on the above mentioned safety and Barlow-Proschan measures.

Birnbaum reliability measure

Birnbaum reliability measure [3] defines the difference between the probability of the transition of the system into the down state, when the i -th component is down at the time t and the probability of the transition of the system into the down state, when the i -th component is up at time t . Birnbaum reliability importance measure plot for the analyzed system is shown in Fig. 4.

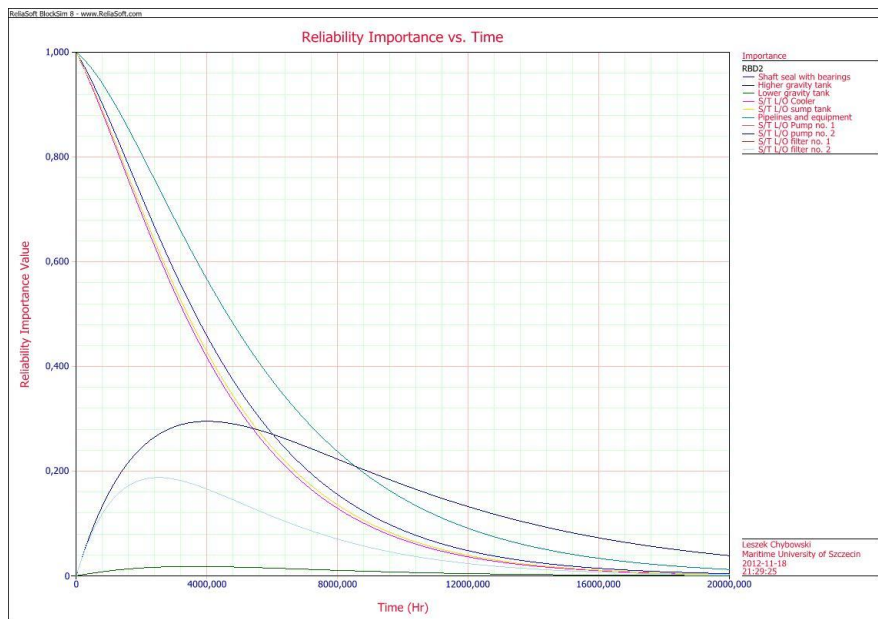

Fig 4. Birnbaum measure of reliability as a function of time for the components of the analyzed system.

Birnbaum measure of the i -th component at time t , as a function of the partial derivative of the system unavailability $Q_0(t)$ relative to the unavailability of the i -th element, which can be represented as:

$$I^B(i | t) = \frac{\partial Q_0(t)}{\partial q_i(t)} = \frac{\partial Q[\bar{q}(t)]}{\partial q_i(t)} \quad (9)$$

where $\bar{q}(t) = [q_1(t), q_2(t), \dots, q_n(t)]$ is an unavailability vector of the operating system components at the time t , and $Q_0(t) = Q[\bar{q}(t)]$ is the unavailability of the system.

The Vesely-Fussell measure

Vesely-Fussell [28] measure describes the probability that the system enters the unavailability due to the unavailability of the i -th component, assuming that the system has failed. The plot of Vesely-Fussell importance measure for the analyzed system is shown in Fig. 5.

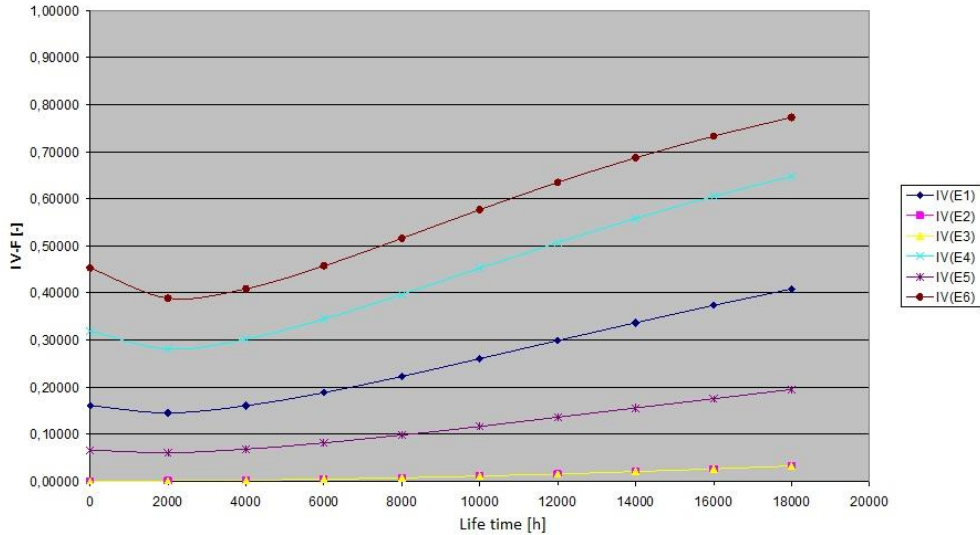

Fig. 5. A Vesley-Fussell importance measure in the function of time for the components of the analyzed system.

Let $\Phi[\bar{X}(t)]$ be a function of the system structure, such that it takes the value 0 when the system is in its down state and 1 when it is in its up state, and determined by the zero-one vector $\bar{X}(t)$, whose components take the value 0 if the appropriate component is down, and 1 if the component operates properly. If m specifies the minimum number of cross-sections which contain the i -th component, the minimum $C_{ij}(t)$ – j -th cross-section containing the i -th component and failing at the time t , $D_i(t)$ – a set comprising at least one cross section of $C_{ij}(t)$, which is unavailable at time t , which can be presented in the following way:

$$D_i(t) = C_{i1}(t) \cup C_{i2}(t) \cup \dots \cup C_{im_i}(t) \quad (10)$$

Vesely-Fussell importance measure is then defined as follows:

$$I^{VF}(i|t) = P\{D_i(t) | \Phi[\bar{X}(t)] = 0\} \quad (11)$$

Reliability improvement potential

Reliability improvement potential [28] can be interpreted as the probability that the i -th component is critical (Cr – component down lead to system down) and down in time t , which can be represented and expressed by the following formula:

$$I^P(i|t) = P\{Cr[\bar{X}(t), X_i = 1] \cap [X_i(t) = 0]\} \quad (12)$$

Between the Birnbaum reliability measure of importance and the reliability improvement potential there occurs the following relationship:

$$I^P(i|t) = I^B(i|t) \cdot q_i(t) \quad (13)$$

The reliability improvement potential plot for the analyzed system has been presented in Fig. 6.

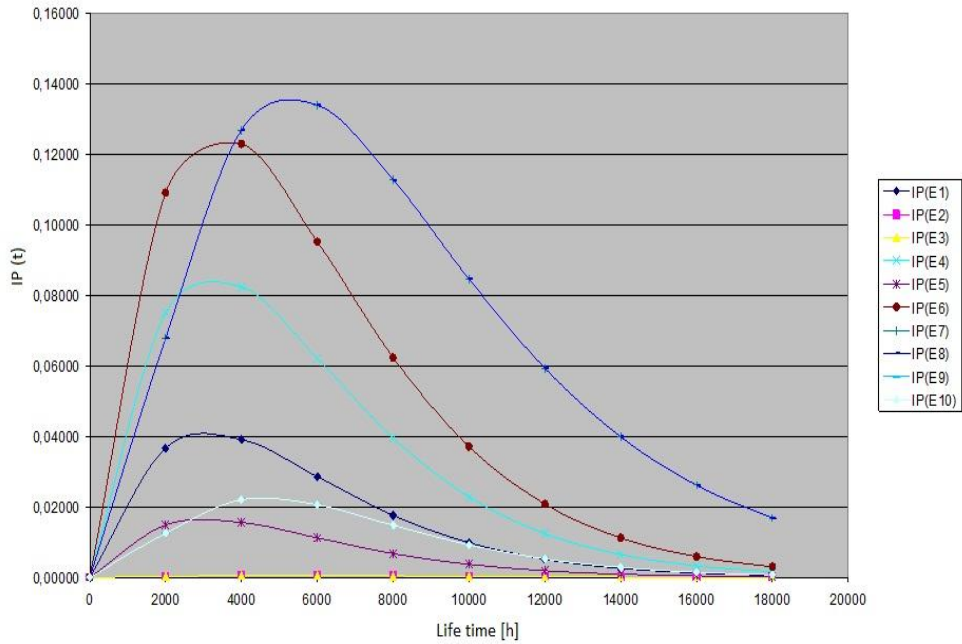

Fig. 6. Reliability improvement potential as a function of time for the components of the analyzed system.

Reliability measure of criticality

Reliability measure $I^{CR}(i|t)$ is defined as the probability that the i -th component is critical to the system and is down in time t , under the assumption that the system is down at time t [16].

Criticality measure can be related to a reliability measure of Birnbaum importance in the following way:

$$I^{CR}(i|t) = \frac{I^B(i|t) \cdot q_i(t)}{Q_0(t)} \quad (14)$$

The plot of the reliability measure of criticality for the analyzed system is shown in Fig. 7.

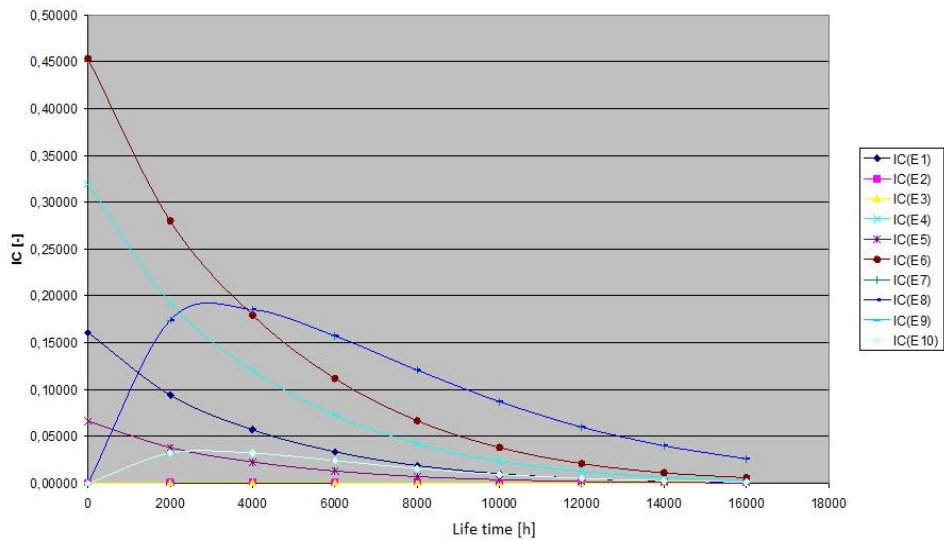

Fig. 7. Reliability measure of criticality as a function of time for the components of the analyzed system.

Barlow-Proschan measure

One of the most commonly used importance measures independent of time duration is Barlow-Proschan measure [1], equal to the probability that the cause of the system down state is the failure to the i -th component. This measure can be considered as "averaged Birnbaum measure" due to unreliability value of a component:

$$I^{BP}(i) = \int_0^{\infty} f_i(t) \cdot I^B(i|t) \cdot dt \quad (15)$$

The value of the Barlow-Proschan importance measure for the analyzed components of the system is shown in Fig. 8.

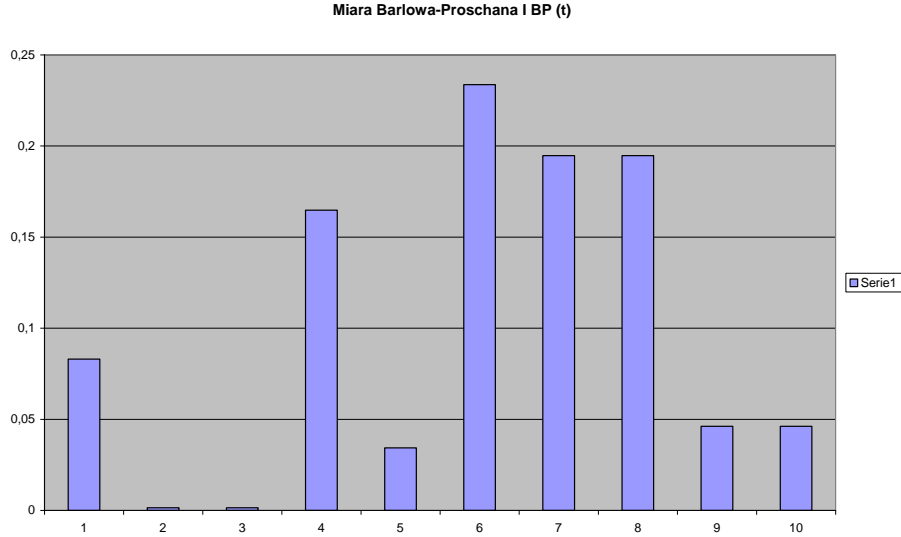

Fig. 8. Barlow-Proschan importance measure for the components of the analyzed system.

Safety measure of importance

Due to a possible emergency caused by damaged components, it is necessary to assign potential damage consequences to each component's down states of the whole system and its surrounding. Knowledge based on case studies, statistics, disasters and accidents at work as well as expert knowledge turns out to be useful in this situation. The author has assumed a safety coefficient obtained by surveying 30 experts and designated it as:

$$I^{SAFETY}(i) = \frac{K(i)}{\max_{k=1..n} K(k)} \quad (16)$$

Where: K is the average value of measure of failure results determined by experts, such that: 0 - no impact of a component failure on the threat of an emergency state; 2 - small emergency risk; 5 - medium consequences of failure, accident of an operator possible; 8 - serious consequences for the service and the environment, the risk of a fatal accident; 10 - the most serious consequences of failure, possibility of loss of life by the members of the crew, the risk of sinking the ship, possibility of an environmental disaster.

n - number of system components.

The value of the importance measure $I^{SAFETY}(i)$ for components of the analyzed system shown in Fig. 9.

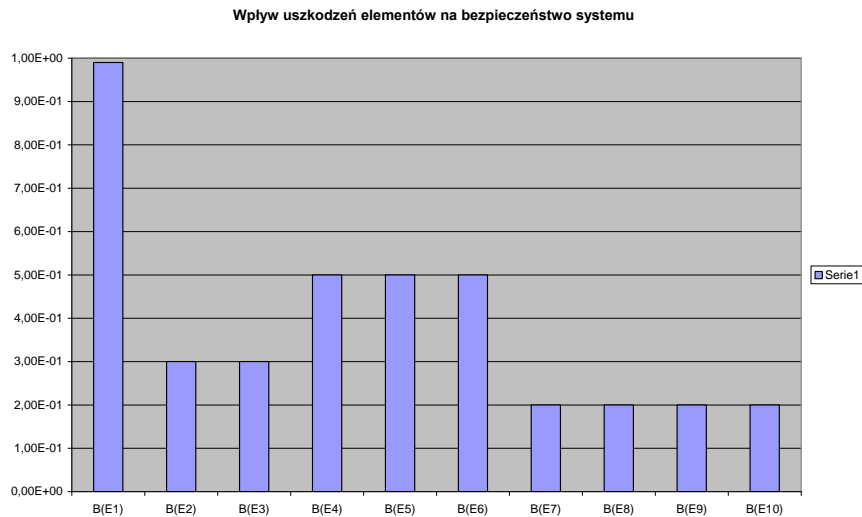

Fig. 9. The component importance measure taking into account failure consequences in terms of operational safety.

Two-criteria importance of a component

Depending on the adopted criteria and the available information about the components of the system, it is possible to draw up a multi-criteria ranking of the importance of components, which needs measures based on the selected importance criteria to be determined (Fig. 10).

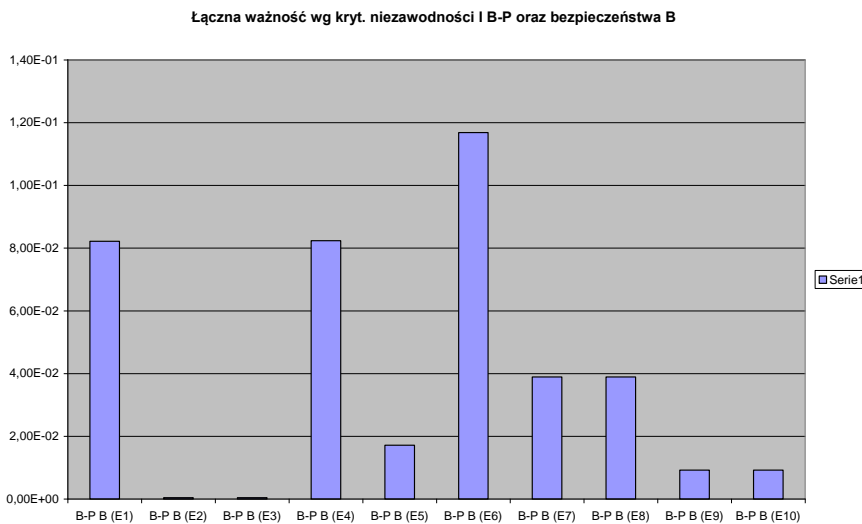

Fig. 10. Combined importance measure concerning the importance of components in terms of reliability and safety.

The author conducted a sample analysis concerning reliability importance in the form of Barlow-Proschan measure and component importance in terms of safety, using the previously presented measure (3.8). The combined measure was determined simply according to:

$$I^{SAFETY-BP} = I^{SAFETY}(i) \cdot I^{B-P} \quad (17)$$

After further research some weighting coefficients will be determined and averaged value will be obtained.

4. Conclusions

One of the more serious problems during the analysis of the significance of components in the reliability structure of a system is the lack of reference of reliability rankings to the impact of a down component on a possible emergency state during the operation of the system. Weak links, which is the most unreliable components of the system, are usually not relevant elements in terms of safety and reliability.

As can be seen from the cited in the paper analyses, the importance ranking based on a specified measure varies over time as a result of certain reliability parameters of the system components and the reliability structure in which the component is located. Therefore, more complete results can be provided by the analysis of time plot of importance measures rather than a static ranking, related to a specific point in time of operation.

The main objective of further research could be the development of theoretical formulations and methods that allow for importance quantitative and qualitative analysis of the real components of complex technical systems with variable reliability structure. Due to the difficulties in the description of the safety system which are easier to express in terms of qualitative than quantitative aspect [2], it seems appropriate to create a combined qualitative and quantitative methodology to assess the importance of components of complex technical systems. Also methods that allow for comparison of the features of different nature and description can be used in further work aiming at the unification of assessment of the importance of components when using multiple importance criteria. The author believes that for this purpose it will be advisable to use the AHP method known in decision-making systems and some hybrid methods [17, 18, 25, 27].

The article does not examine the importance on the basis of other criteria listed in the introduction, since it is the author's intension to undertake the task in his further works. The significance of importance analysis of components from the point of view of the economics of the operation process should be noted here. Currently, there are few publications that address this issue [14], but in the author's opinion it is still not enough.

Acknowledgments: The author's research presented in this article was carried out by the project: Grant NCN 2011/01/D/ST8/07827: "Importance analysis of components in reliability structure of complex technical systems on example of marine power plant."

5. References

- [1] Barlow R. E., Proschan F.: Importance of system components and fault tree events, SPaTA, Vol. 3, 153-173, 1975.
- [2] Burnos A., Banaś D.: FMECA w służbie utrzymania ruchu, Służby Utrzymania Ruchu 4/2012, Forum Press, Poznań 2012
- [3] Birnbaum Z. W.: On the importance of different components in a multicomponent system, Multivariate analysis-II, New York, USA, Academic Press, 581-92, 1969.
- [4] Chybowski L.: Assessment of Reliability and Availability of Fishing Vessels Power, Propulsion and Technological Plants Based on Fault Tree Analysis, Polish Journal of Environmental Studies, Vol. 18, No. 2A, 39-44, 2009.
- [5] Chybowski L.: Application of External Events Vectors for Defining Reliability Structure of Fishing Vessels Power, Propulsion and Technological Plants, Polish Journal of Environmental Studies, Vol. 18, No. 2A, 45-50, 2009.
- [6] Chybowski L.: Tendencje rozwojowe w ocenie ważności elementów i grup elementów w strukturze niezawodnościowej systemów, Studia i Materiały Polskiego Stowarzyszenia Zarządzania Wiedzą, Nr 45, Bydgoszcz, 77-86 2011.
- [7] Chybowski L.: Jakościowo-ilościowa analiza ważności elementów w strukturze niezawodnościowej systemów, Studia i Materiały Polskiego Stowarzyszenia Zarządzania Wiedzą, Nr 45, Bydgoszcz, 67-76, 2011.
- [8] Chybowski L.: A Note On Modifications To The Methodology For Components In The Complex Technical Systems Reliability Structure Importance Evaluation, Journal of Polish CIMAC Vol. 6 No. 2, Diagnosis, Reliability and Safety, Gdańsk, 59-64, 2011.
- [9] Chybowski L.: A New Approach To Reliability Importance Analysis of Complex Technical Systems, Journal of Polish CIMAC Vol. 6 No. 2, Diagnosis, Reliability and Safety, Gdańsk, 65-72, 2011.
- [10] Chybowski L.: Safety criterion in assessing the importance of an element in the complex technological system reliability structure, Management Systems in Production Engineering, Vol. 1(5), 10-13, 2012.
- [11] Chybowski L.: The problems of modelling the reliability structure of the complex technical system on the basis of a steam-water system of the engine room, Management Systems in Production Engineering, Vol. 2(6), 12-17, 2012.

- [12] Dudziak A.: Najnowsze rozwiązania w armaturze wodociągowej, *Wodociągi – Kanalizacja*, Vol. 7-8, 2007.
- [13] Dudziak A.: Armatura w nowoczesnych układach grzewczych i przygotowania c.w.u., *Polski Instalator*, Vol. 3, 2011.
- [14] Hilbert P.: Component reliability importance indices for maintenance optimization of electrical networks, Licentiate thesis, Royal Institute of Technology, Stockholm 2005.
- [15] Jaźwiński J., Borgoń J.: Niezawodność eksploatacyjna i bezpieczeństwo lotów, WKiŁ, Warszawa 1989.
- [16] Karpiński J., Korczak E.: Motody oceny niezawodności dwustanowych systemów technicznych, IBS PAN, Omnitech Press, Warszawa, 162-165, 1990.
- [17] Liberadzki R.: Risk criteria for sea-going ships arising from the operation of the main engines'crankshaft - connecting rod - piston systems, *Journal of Polish CIMAC*, Vol. 7, no 2, 115-121, 2012.
- [18] Liberadzki R.: Effect of adopted rules of inference and methods of defuzzification on the final result of evaluation of reliability made using the fuzzy logic methods, *Journal of Polish CIMAC*, Vol. 6, no 2, 157-162, 2011.
- [19] Liberadzki R.: Selected aspects of determining the reliability of the pump subsystems with redundancy, used in main engine auxiliary systems, *Journal of Polish CIMAC*, Vol. 5, no 2, 108-113, 2010.
- [20] Kuo W., Zhu X.: *Importance Measures in Reliability, Risk, and Optimization: Principles and Applications*, Wiley 2012.
- [21] Lazakis I., Turan O., Aksu S.: Increasing ship operational reliability through the implementation of a holistic maintenance management strategy, *Ships and Offshore Structures*, Vol. 5, No. 4, 337–357, 2010.
- [22] Matuszak Z., Nicewicz G.: Assessment of excess power factor in marine generating sets, *Journal of Polish CIMAC*, Vol 3, 95-101, 2008.
- [23] Matuszak Z., Nicewicz G.: Models of periodically switched on and off electrical equipment operation, *Problemy Eksploatacji*, No 2, 185-193, 2008.
- [24] Matuszak Z., Nicewicz G.: Assessment of whether marine power plant steam system failures belong to one general population, *Journal of Polish CIMAC*, 139-151, 2010.
- [25] Pietruszkiewicz W., Twardochleb M, Roszkowski M.: Hybrid approach to supporting decision making processes in companies, *Control and Cybernetics*, Vol. 40, No. 1, 125-143, 2011.
- [26] Niezawodność okrętowych siłowni spalinowych. Sformułowanie problemu i propozycja jego rozwiązania, Raport techniczny Nr RT-95/T-01, Centrum techniki Okrętowej, Gdańsk 1995.

- [27] Twardochleb M. R., Rychcicki R.: Efficiency of hybrid optimization method in solving tasks of verified characteristics, *Metody Informatyki Stosowanej*, No. 4, 135-145, 2009.
- [28] Vatn J.: Finding minimal cut sets in a fault tree, *Reliability Engineering and System Safety*, Vol. 36, 1992, s. 59-62.
- [29] Vessel specification. Engine room systems. 6,500 TEU Class Container Carrier.



Dr. Leszek Chybowski is Assistant Professor in the Institute of Ship Power Plant Operation of the Faculty of Marine engineering of Maritime University of Szczecin. He graduated Maritime University of Szczecin in 1999. Since this year, he has been working as marine engineer officer onboard deep sea and offshore vessels. From 2005 he is an academic at Maritime University of Szczecin. In 2007 he recieved PhD for thesis "Applications of specific analytical algorithms for the estimation of offshore vessel power plant systems unavailability". Mr. Leszek Chybowski does research aimed at improving of the reliability and safety of technical systems as well as increasing of efficiency of its operation in terms of preventing damage. Dr. Leszek Chybowski is the author of over 70 domestic and foreign publications on reliability, safety and diagnostics of technical systems. The results of his research were presented in the more than 30 symposia and conferences in Poland and abroad.